

## RM2006 INFORMATION



February 2006

## RM2006 New Features, Improvements and Detailed Bridge Module Overview

With implementing a sophisticated **CFD** code (based on the **vortex particle method**) for supporting **dynamic wind analyses** from the very beginning onwards, and with the **new erection control facility** combined with novel **FEM** features, **TDV** once again forges ahead and challenges the competitors as it did years ago by first introducing the 4<sup>th</sup> dimension in standard bridge analyses.

Indeed, due to the variety of functions supporting almost any special analysis tasks arising in the bridge design process, already the previous version **RM2004** was a nearly indispensable tool for all bridge engineers facing problems requiring a treatment somehow exceeding the very banal everyday design process. Therefore, for those engineers, who are not at all familiar with **RM**, it seems to be indicated to give here a **short summary** of the comprehensive functionality of the program.

**The Geometric Pre-processor GP** allows for easily defining the structural model of any bridge structure. Complicated geometric conditions can easily be recorded by defining “axes” in plan and elevation view, with using all geometric elements (straight, circular, parabolic, spiral, etc) commonly known in road construction. Extensive graphic input facilities allow for efficiently constructing any type of bridge cross-section on the screen. The superstructure segments are allocated by placing the different cross-sections along these axes. These “segments” relate the physical model to the structural model (elements, nodes).

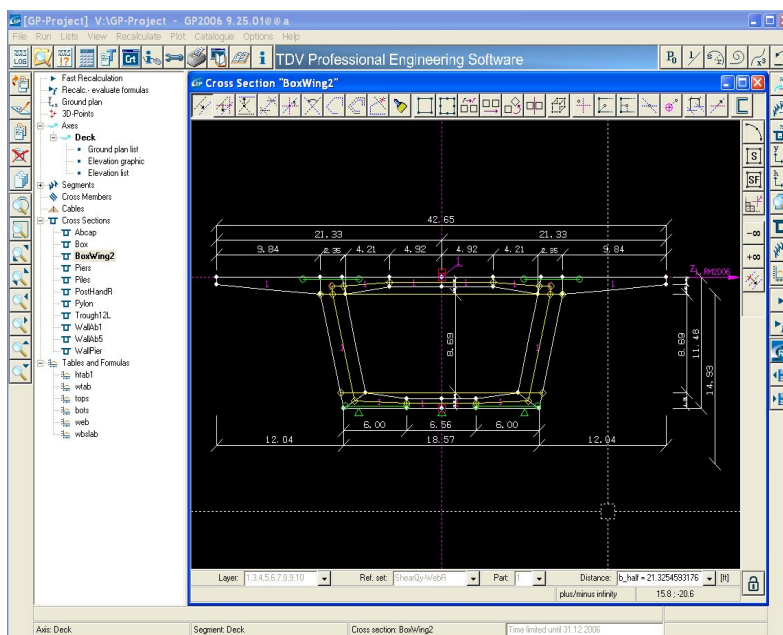

Figure 1: Cross Section modelling

Special types of segments define cross-girders of **truss models** (link segments), temporary support conditions in incremental launching processes (ILM-segments) or substructure entities like abutments, piers or pile groups.

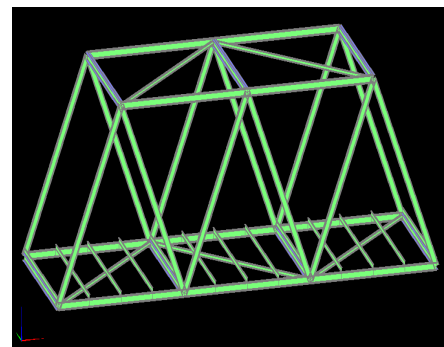

Figure 2: Truss modelling with link segments

A very interesting recent development aims at analyzing **bascule bridges** and allows for arranging model parts in different positions and directions within the different construction stages.

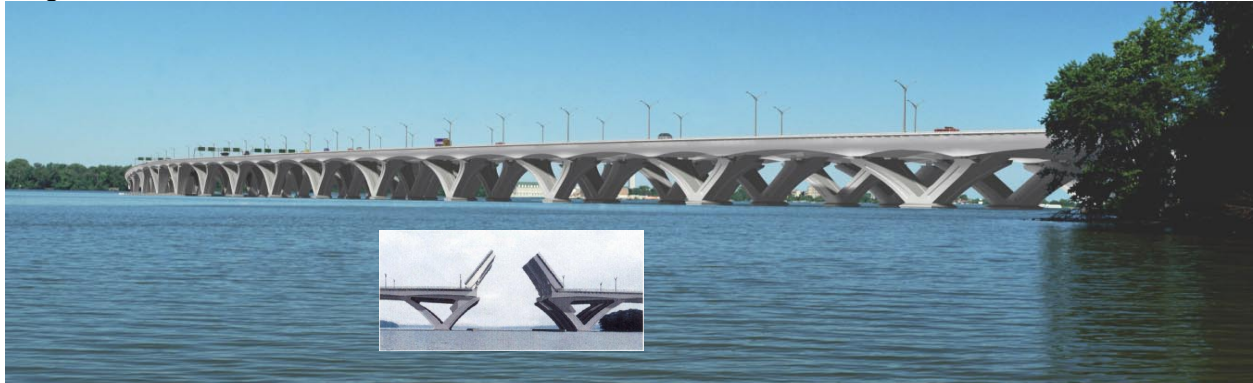

Figure 3: Woodrow Wilson - bascule bridge

**The analysis part RM** not only allows full non-linear analyses for all types of bridge structures, but also contains special design check modules for proof-checking stability and serviceability in accordance with most national design codes worldwide. These functions: ultimate load check for reinforced and/or pre-stressed members, shear checks, robustness checks etc. include sophisticated procedures, developed by modern programming methods, and therefore change the **RM SOLVER** in a **POWERFUL** and **QUICK** calculation tool! Reinforcement design functions are included in these checking modules; they determine the required additional reinforcement if needed.

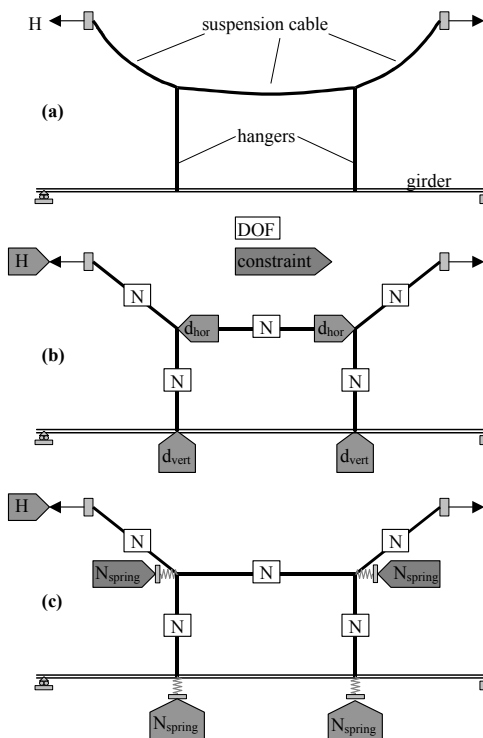

Figure 4: Optimisation for shape finding at suspension bridges

**Optimisation procedures** (e.g. for evaluating the required stay cable stressing sequence in order to achieve a given maximum stress state in the superstructure, for optimisation of tensioning of temporary stays) are **another great help in the design process**. The algorithm implemented in **RM2006** models in detail every construction stage. The tensioning of each single cable is considered at first as a unit load case taking into account the current structural system and then influencing all previously applied unit load cases. All other loadings (e.g.: self weight of the new segment, moving the traveller etc.) related to the individual erection procedure are also calculated step by step. All displacements and internal forces are accumulated and divided into one „constant“ (self weight etc.) and several „variable“ components. Each „variable“ component is related to one tensioning unit loading case and optimised in additional constraint module.

**Evaluating the optimal tensioning strategy with RM2006 yields considerable savings in costs and time.**

**Special program modules** exist for supporting the different needs of different bridge types, such as reinforced and pre-stressed concrete bridges, composite structures, cable stayed and suspension bridges, etc. It is worth while mentioning, that the program uses a consistent approach for properly taking into account all creep and shrinkage effects as well as pre-stressing steel relaxation in accordance with the relevant design codes or proposals of international institutes like **CEB-FIP**.

One of the emphases of the past few years was the steady improvement of the **dynamic analysis** functionality beyond standard forced-vibration and earthquake-response analyses. This was mainly done – on the one hand – due to the demands of the **high-speed railway systems** currently being established in many countries, and – on the other hand – with respect to the rising amount of long-span bridges requiring sophisticated dynamic wind analyses. This effort resulted in a very efficient module for performing **rolling stock analyses** taking into account moving loads as well as moving masses.

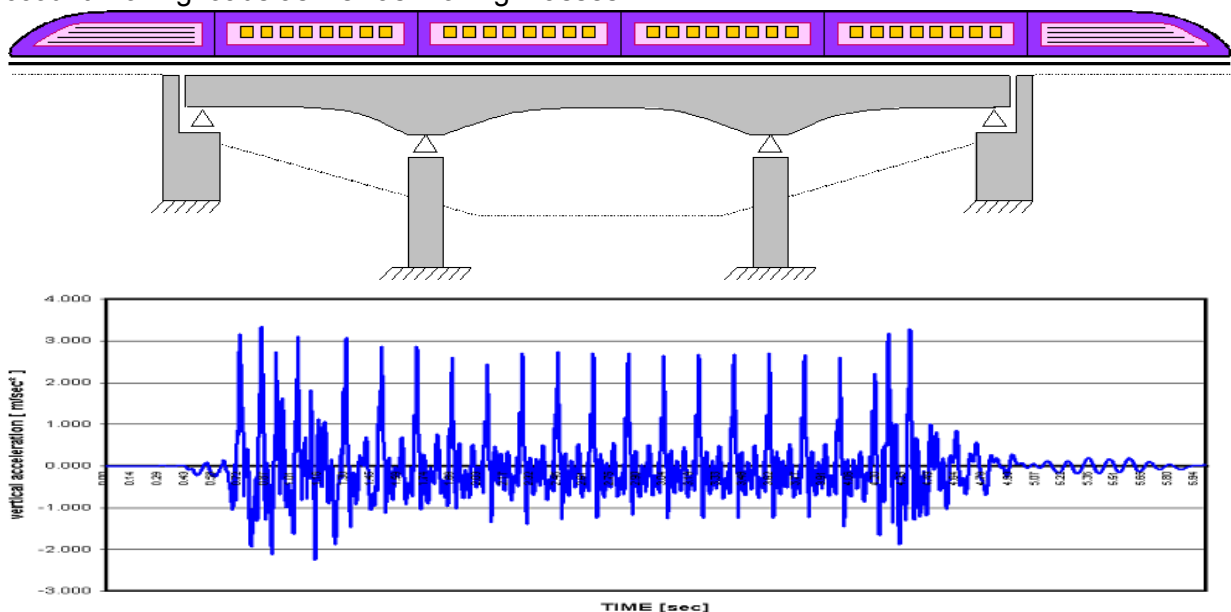

Figure 6: Structural accelerations due to passing of High Speed Train

This module is currently used in a big **research project of the Austrian railway authority** where **TDV** is involved. It aims at checking the high-speed serviceability of all existing bridges along potential high-speed railway lines.

The **wind related functions** match nearly all needs for the design of long-span bridges. Arbitrary complicated wind profiles with varying wind speed and turbulence intensity in

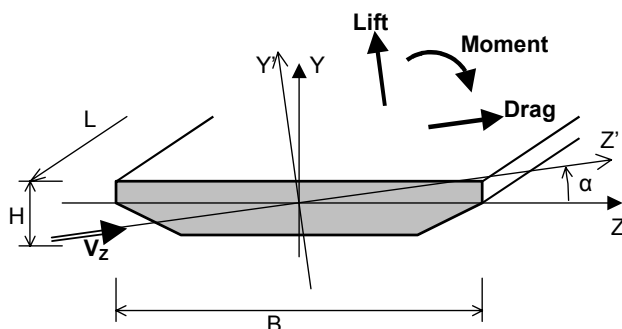

Figure 7: Wind forces action on the bridge section

accordance with different national design codes can be easily defined. Together with the cross-section related shape factor diagrams defining the dependency of the drag- lift- and moment coefficients on the attack angle of the wind impact, these wind profiles allow for performing a comprehensive wind buffeting analysis taking into account the varying along-wind and lateral forces of gusty wind events.



The structural wind buffeting calculation is performed in the modal space and in the frequency domain. It includes aerodynamic damping and stiffness effects due to structural movement caused by the wind flow. All computations are based on the tangential stiffness of the structure at a given point in time – the structure under permanent loading and mean wind - ensuring the inclusion of all non-linear effects which may have taken place prior to the stochastic wind event.

Further **improvements in the GUI** are made for an easier and more intuitive usage as it was already before.

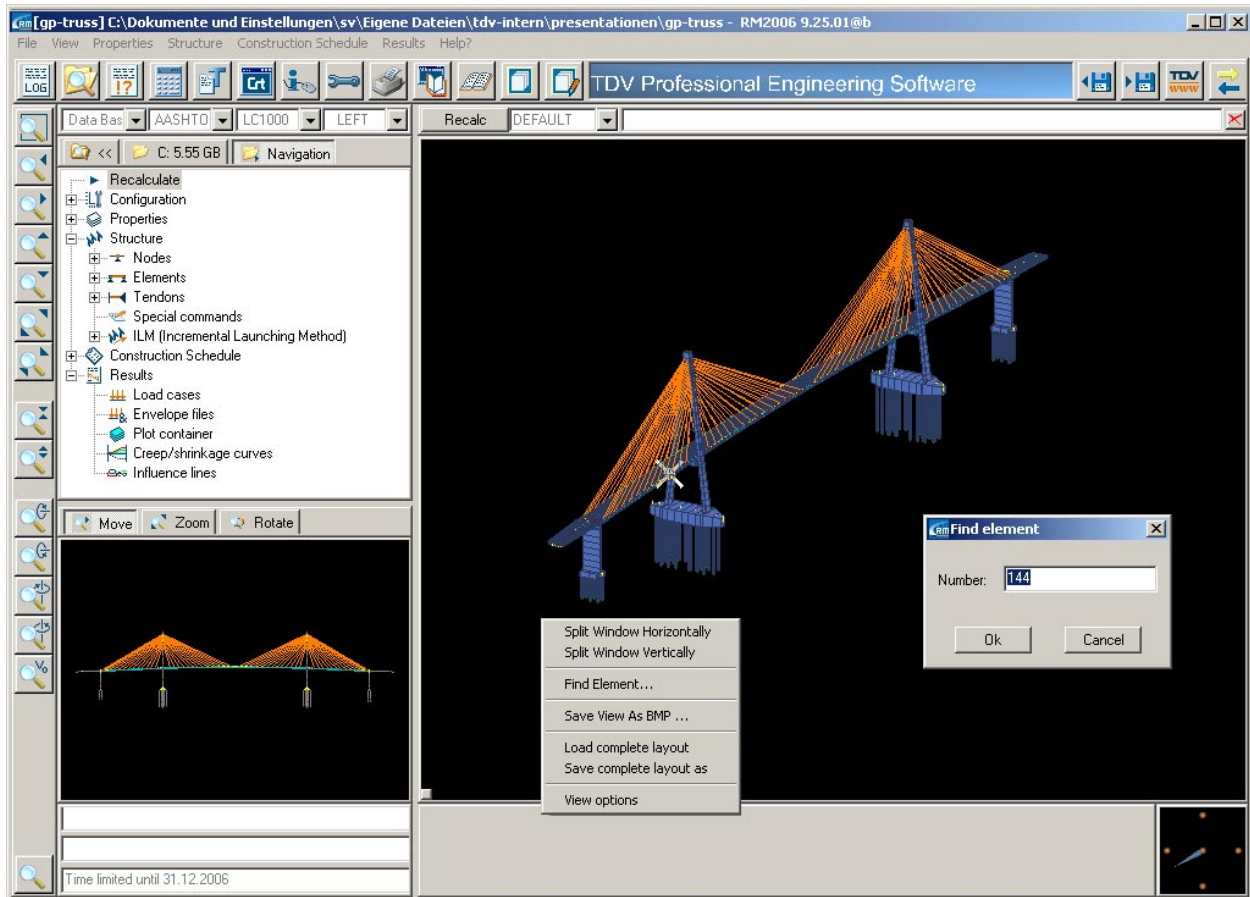

Figure 8: Improved GUI-handling

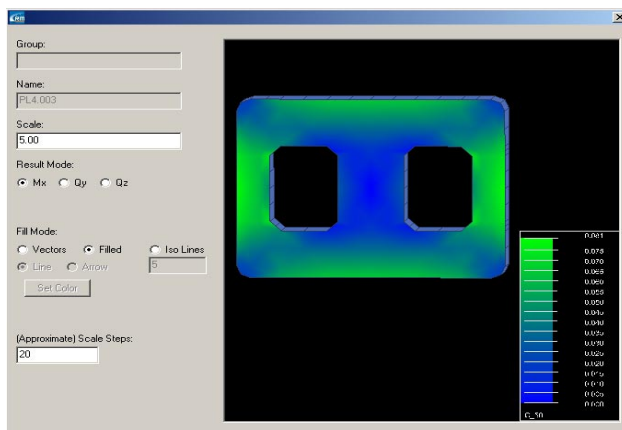
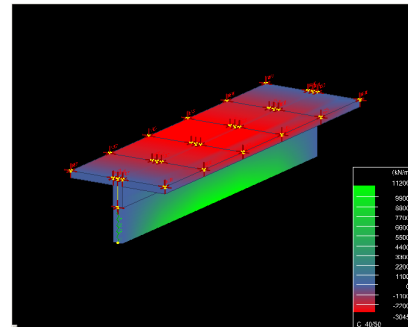
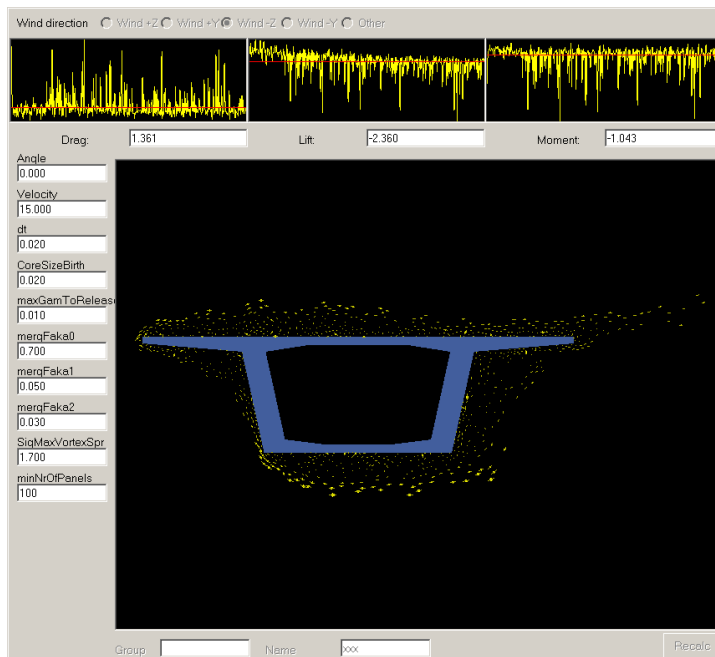

Figure 9: Local stress distribution

The new version **RM2006** also includes novel **FEM** features for better considering warping effects and local stress distribution.



One of the most notable enhancements of **RM2006** is the implementation of a **CFD code**, calculating the forces on the cross-sections due to **turbulent airflow** around them.



An automatic variation of the wind direction directly creates the relevant shape coefficient diagrams, which up to now had to be evaluated from extensive wind tunnel tests unless relevant values could be found in public literature.

Figure 10: New RM2006 CFD module, based on the "Vortex particle" method

The other outstanding extension of **RM2006** is the **erection control facility**. TDV's erection control module allows not only predicting and monitoring the bridge erection process but also solves forward and backward problems in the bridge design process. With extending the existing solver by using a novel numerical method, **RM2006** is now able to run structural analyses in different calculation modes controlled by the user.

**The user can perform forward calculation, backward calculation, erection control or erection monitoring with the same software.**

In classical design mode the engineer is usually choosing the target geometry and a force/stress distribution in the service state. **RM2006** fits the structure into the target position and constrains the chosen force/stress distribution by calculating segment fabrication shapes, stress free lengths of the cables, section shop-forms and a pre-camber line for each stage.

In the erection control mode **RM2006** simulates the erection procedure based on the design segment fabrication shapes and the stress free cable lengths. **RM2006** gives information if force action on site is necessary by assembling the new segments. This allows determining any necessary equipment and possible construction problem already in the early design stage.

In the erection monitoring mode **RM2006** allows continuously monitoring the erection procedure on site. Any deviation from the predicted pre-camber line is input in the program and **RM2006** supports the engineer to fix the future changes in the erection steps by using the inbuilt optimisation tool.

**Both, linear and non-linear analyses are now performed on the displaced structure, taking into account the exact geometrical lengths and rotations.**

This comprehensive solution simplifies design and erection control of the bridge, efficiently using the same procedure for all kinds of bridges from small concrete bridges to big stay cable bridges like **Sutong Bridge** in China, and extra-large suspension bridges like **Messina Bridge** in Italy.



*Figure 11: The RM2006 erection control module will be used for Sutong bridge*